



# *City of Niagara Falls, New York*

745 Main Street  
Niagara Falls, New York 14301  
Purchasing Division, Room 214  
(716) 286-4371

June 14, 2023

**RE: Niagara Falls Water Board Bid #W2023-01  
Water and Sewer Construction and Repair**

Dear Vendor,

Please find enclosed a copy of the above referenced request for bids package. We have revised our specifications and therefore strongly encourage vendors to read each specification carefully.

Should you have any questions please feel free to contact me.

Very truly yours,

Leeann K. Huey  
Purchasing Agent

LKH  
Enc.



# NIAGARA FALLS WATER BOARD

**REQUEST FOR SEALED BIDS FOR:  
 WATER AND SEWER CONSTRUCTION AND REPAIR MATERIALS  
 BID #W2023-01**

Sealed submissions will be received, publicly opened and read aloud on behalf of the Niagara Falls Water Board (NFWB) by the Purchasing Office of the City of Niagara Falls at City Hall as follows:

Time

Date

10:00 A.M.

WEDNESDAY, JULY 12, 2023

FOR: PURCHASE OF WATER AND SEWER CONSTRUCTION AND REPAIR MATERIALS

in accordance with the specifications on file. The Niagara Falls Water Board reserves the right to reject any and all submissions, and waive any informality.

One (1) original submission and one (1) copy shall be submitted to:

CITY OF NIAGARA FALLS, NEW YORK  
 DIVISION OF PURCHASING  
 City Hall, Room 214  
 745 Main Street  
 Niagara Falls, NY 14301

**BIDS SUBMITTED BY FACSIMILE OR ELECTRONIC MEANS ARE UNACCEPTABLE**

All bids are subject to delivery and must comply with the delivery specifications contained herein.

If a bid is submitted on an article intended as a substitute for a grade or brand specified, the vendor shall state the grade or brand of the substitution, otherwise it will be assumed that the bid is based upon the grade or brand specified.

The Board reserves the right to accept this bid by items, or as a whole, or to reject any and all bids or waive informalities.

Bid prices are to be shown NET. Cash discounts, if any, are to be clearly stated.

Prices must be filled in mechanically or in ink on this form and placed in a **SEALED ENVELOPE CLEARLY MARKED WITH THE BID NUMBER AND THE NAME OF THE VENDOR SUBMITTING THE BID.**

Any and all bids and contracts made or awarded by the Board, or any department, agency or official thereof for work or services performed or to be performed, or goods purchased or sold or to be purchased or sold are made subject to the provisions of Chapter 861 of the Laws of New York, 1953, as amended by Chapter 751 of the Laws of New York, and as now contained or may hereafter be amended. The provisions of the New York State General Municipal Law, including Sections 103a and 103b, are applicable to this bid.

**VENDOR'S ATTENTION IS REQUESTED REGARDING THE FOLLOWING CONDITIONS AND REGULATIONS. BIDS NOT IN COMPLIANCE WITH THE CONDITIONS AND REGULATIONS CONTAINED HEREIN WILL NOT BE CONSIDERED**

**NON-COLLUSIVE BIDDING CERTIFICATION  
(PURSUANT TO CHAPTER 751 OF THE LAWS OF NEW YORK, 1965)**

**By submission of this bid, the vendor certifies that:**

- 1) This bid has been independently arrived at, without collusion with any other bidder or with any competitor or potential competitor;
- 2) This bid has not been knowingly disclosed and will not be knowingly disclosed, prior to the opening of bids or proposals for this project, to any other vendor, competitor or potential competitor;
- 3) No attempt has been or will be made to induce any other person, partnership or corporation to submit or not to submit a bid;
- 4) The person signing this bid certifies that he has fully informed himself regarding the accuracy of the statements contained in this certification, and under the penalties of perjury, affirms the truth thereof, such penalties being applicable to the vendor as well as to the person signing on its behalf;
- 5) That attached hereto (if a corporate vendor) is a certified copy or resolution authorizing the execution of this certificate by the signing party on behalf of the corporate bidder.

**Anti-Discriminatory Statement:**

All programs, policies, procedures, procurement opportunities and activities conducted by and through this organization, its employees, contractors and subcontractors shall be conducted without regard to age, ancestry, color, creed, citizenship (where applicable), gender, genetic information/testing, marital

status, mental or physical disability, political affiliation, belief or opinion (where applicable), national origin, race, religious affiliation, belief or opinion, sex (except where age, sex, or disability involves a bona fide occupational qualification), sexual orientation (where applicable) or status as a participant in Workforce Investment Act (WIA) funded programs (where applicable). The Board encourages participation of women and minority owned business enterprises in all its procurement opportunities and has a goal of increasing participation of MWBE organizations in its procurement activities.

**VENDOR NAME:**

\_\_\_\_\_

**VENDOR ADDRESS:**

\_\_\_\_\_

\_\_\_\_\_

\_\_\_\_\_

CONTACT PERSON FOR QUESTIONS REGARDING BID: \_\_\_\_\_

CONTACT PERSON'S TELEPHONE NUMBER: \_\_\_\_\_

AUTHORIZED SIGNATURE: \_\_\_\_\_

NAME AND TITLE: \_\_\_\_\_

DATE: \_\_\_\_\_

=====

**MAIL BIDS TO:**

NIAGARA FALLS WATER BOARD  
C/O PURCHASING DIVISION, ROOM 214  
745 MAIN STREET  
NIAGARA FALLS, NEW YORK 14301

**DELIVER BIDS TO:**

NIAGARA FALLS WATER BOARD  
C/O PURCHASING DIVISION, ROOM 214  
745 MAIN STREET  
NIAGARA FALLS, NEW YORK 14301

## SPECIFICATIONS AND TERMS (Page 1 of 2)

1. Bids will be received by the City of Niagara Falls Purchasing Division, 745 Main Street, Room 214 on behalf of the Niagara Falls Water Board ("Board") at 745 Main Street, Niagara Falls, New York 14301, Room 214 until 10:00 a.m. on July 12, 2023 for the purchase of water and sewer construction and repair materials as described herein and opened at that time.
2. The term of this contract/agreement shall be for one (1) year from the date of award. All pricing must remain firm for the entire aforementioned term.
3. Following the opening of the valid submissions, the Board will conduct its due diligence. Once the due diligence investigation is completed, the Board shall either reject all bids or the lowest responsible bid will be submitted to the members of the Board for possible award via majority vote.
4. Upon award of this offering, the successful vendor(s) must also submit to the Purchasing Division certificates of insurance which meet all of the requirements set forth in the attached "Niagara Falls Water Board Insurance Requirements." Said certificates of insurance must be received by the Purchasing Division no later than ten (10) business days following the date of notification of award. Failure to do so may result in the award being negated.
5. All materials are to conform to the most recent appropriate A.W.W.A standard and be of the manufacturer's most recent improved design.
6. Deliveries are to be made to 1201 Buffalo Avenue, Niagara Falls, New York 14303 unless another destination within the City of Niagara Falls is specified at the time of order.
7. Deliveries for fire hydrants must be made within seventy five (75) days of receipt of order. All other items must be delivered within sixty (60) days after receipt of order.
8. Vendors shall quote an item price for each item, and said item price shall be F.O.B. destination, freight prepaid.
9. Where indicated, the quantities listed on the price sheet are estimated quantities to be ordered. Where no estimate is given, the Board is uncertain as to its estimated need of these items during the contract period. Items will be ordered as needed, and the Board reserves the right to order more or less than the quantities listed. No guarantees are made as to minimum or maximum quantities the Board will require.
10. The Board reserves the right to award grouped items of varying sizes (e.g. Bushings, Brass Nipples, Curb Stops, etc.) to a single vendor rather than to multiple vendors, for expediency in order placement and receipt of goods.
11. Attached hereto as **Appendix D** are specific specifications and drawings for fire hydrants, catch basins, manhole frames and covers, valve box height adapters and catch basin traps, frames and

## SPECIFICATIONS AND TERMS (Page 2 of 2)

grates. Please refer to these specifications to ensure that items meet the Board's specific needs before bidding.

12. Failure to supply any requested information, or to submit prices for all items may cause a submission to be considered informal or result in a vendor being declared non-responsible.
13. Vendors shall note there are four (4) appendices attached to these specifications. Vendors must complete all of the documents contained in said **Appendices A through C** and also provide all materials which meet the requirements set forth therein, including but not limited to, a certificate of insurance meeting the Niagara Falls Water Board standard insurance requirements, which must be provided by the successful bidder(s) after award of the bid.
14. Failure to complete and/or provide the materials set forth in the exhibits may result in the submission being rejected.
15. Submissions hereunder are also being sought on behalf of the City of Niagara Falls, a separate and distinct legal entity. As such, the City of Niagara Falls shall have the right to make purchases at the prices set forth in the successful submission.

It is understood that all materials, goods and services provided to the City of Niagara Falls herein shall be invoiced directly to the City of Niagara Falls, Department of Public Works, 1785 New Road, Niagara Falls, New York 14304 and shall be delivered to either that location or to whatever location or locations within the City of Niagara Falls that the City deems appropriate.

The Niagara Falls Water Board will bear no responsibility for any contracts/agreements, invoices, charges or debts incurred by the City of Niagara Falls through this or any other contract/agreement.

16. The Board reserves the right to accept any submission hereunder by items, or as a whole, or to reject any or all items or to waive any informalities in a submission. In case of error in the extension of prices in a submission, the unit price will govern. The Board may also award all items in a particular sub-group or sub-division to a single vendor to ensure product compatibility and efficiency.
17. For questions regarding specific items on this bid, please contact the following:  
Michael Eagler [meagler@nfwb.org](mailto:meagler@nfwb.org) or telephone 716-283-9770 extension 1070  
Bill Wright [bwright@nfwb.org](mailto:bwright@nfwb.org) or telephone: 716-534-4412.
18. For questions regarding these specifications, please contact City of Niagara Falls Purchasing Agent Leeann Huey at 716-286-4372.

**PRICE SHEET ( PAGE 1 of 10)**

**Vendor Name:** \_\_\_\_\_

ITEM #	EST. QTY	UNIT	DESCRIPTION	UNIT PRICE
			<b>STANDARD BURY FIRE HYDRANTS (MUELLER CENTURION KENNEDY GUARDIAN)</b>	
1	5	EA.	4 FT. Bury	
2	15	EA.	5 FT. Bury	
3	5	EA.	6 FT. Bury	
			<b>BREAKAWAY KITS</b>	
4	15	EA.	Breakaway Kits for Kennedy Guardian	
5	15	EA.	Breakaway Kits for Mueller Centurion	
			<b>CAST IRON CURB &amp; VALVE BOX PARTS, ALL SCREW TYPE VALVES AND CURB BOXES SHALL BE AS MANUFACTURED BY BIBBY-ST. CROIX FOUNDRIES INC. OR EQUIVALENT COVERS SHALL BE CAST WITH "WATER" LABEL ON TOP VALVE ROAD BOXES</b>	
6	20	EA.	Bases 14 3/8" base, 8 1/4" top, 12 3/8" high	
7	20	EA.	Top Sections 26"	
8	20	EA.	Top Sections 17"	
9	20	EA.	Bottom Sections 30"	
10	20	EA.	Bottom Sections 24"	
11	20	EA.	Bottom Sections 16"	
12	30	EA.	Shaft Extensions 26"	
13	30	EA.	Shaft Extensions 16"	
			<b>VALVE BOX HEIGHT ADAPTERS (For Adjusting Boxes to Pavement Level)</b>	
14	50	EA.	Slide Type: Adjustment Range 2-1/2" to 8" 10-3/4" Height; 4-3/8" inner diameter	
15	50	EA.	Screw-Type, Adjustment Range 2-1/2" to 8" 16-1/2" Height; 5-1/4" inner diameter	
16	50	EA.	Valve Box Riser V829 Fixed 5-1/4 x 1	
17	50	EA.	Valve Box Riser V830 Fixed 5-1/4 x 1-1/2	
18	50	EA.	Valve Box Riser V831 Fixed 5-1/4 x 2	
			<b>VALVE BOX REGULATOR COVERS 5-1/4"</b>	
19	40	EA.	(MARKED WATER)	

**PRICE SHEET ( PAGE 2 of 10)**

**Vendor Name:** \_\_\_\_\_

ITEM #	EST. QTY	UNIT	DESCRIPTION	UNIT PRICE
<b>CURB BOXES</b>				
20	25	EA.	Bottom 33"	
21	25	EA.	Bottom 24"	
22	25	EA.	Top Section w/Cover 16"	
23	25	EA.	Top Section w/Cover 24"	
24	25	EA.	Extension 9"	
25	25	EA.	Extension 16"	
26	50	EA.	Old Style Repair Lid (Outside Lip)	
27	50	EA.	New Style Repair Lid (Inside Lip)	
<b>CAST IRON VALVE ROAD BOX RISERS</b>				
28	30	EA.	1"	
29	15	EA.	2"	
30	10	EA.	4"	
31	10	EA.	6"	
<b>DUCTILE IRON PIPE - ANSI/AWWA C151/A21.51 CLASS 52 STANDARD 18'-20' LENGTHS - PUSH-ON JOINT</b>				
32	95	FEET	4"	
33	190	FEET	6"	
34	95	FEET	8"	
35	95	FEET	10"	
36	120	FEET	12"	
37	40	FEET	16"	
38	120	FEET	20"	
<b>TRANSITION COUPLINGS (DRESSER TYPE)-COMPRESSION TYPE WITH ALL ACCESSORIES TO ADAPT FROM CAST IRON TO DUCTILE IRON PIPE - CLASS 52 AWWA 151</b>				
39	26	EA.	4"	
40	30	EA.	6"	
41	14	EA.	8"	
42	18	EA.	10"	
43	8	EA.	12"	
44	10	EA.	20"	



**PRICE SHEET ( PAGE 3 of10)**

**Vendor Name:** \_\_\_\_\_

ITEM #	EST. QTY	UNIT	DESCRIPTION	UNIT PRICE
			<b>PVC WATERMAIN - AWWA C900 DR-18 – PER STICK</b>	
45	6	Stick	4"x 20' Length	
46	6	Stick	6"x 20' Length	
47	4	Stick	8" x 20' Length	
48	5	Stick	10"x 20' Length	
49	5	Stick	12"x 20' Length	
50	5	Stick	16"x 20' Length	
51	5	Stick	20"x 20' Length	
52	5	Stick	24"x 20' Length	
53	5	Stick	36"x 20' Length	
			<b>360 DEGREE STAINLESS STEEL REPAIR CLAMPS FORD FS SERIES OR EQUAL: 18-8 TYPE 304 SS 4" to 10" IN ONE SECTION, 12" &amp; 16" IN TWO SECTIONS, OVER 16" IN THREE SECTIONS</b>	
54	10	EA.	4" X 12" 4.75 - 5.15	
55	8	EA.	4" X 12" (w/tapped 1" cc outlet)	
56	5	EA.	4" X 20" 4.75 - 5.15	
57	20	EA.	6" X 12" 6.84 - 7.24	
58	8	EA.	6" X 12" (w/tapped 3/4" cc outlet)	
59	4	EA.	6" X 12" (w/tapped 1" cc outlet)	
60	6	EA.	6" x 20" 6.84 - 7.24	
61	10	EA.	8" X 12" 9.05 - 9.30	
62	6	EA.	8" X 12" (w/tapped 3/4" cc outlet)	
63	6	EA.	8" X 12" (w/tapped 1" cc outlet)	
64	6	EA.	8" X 20" 9.05 - 9.30	
65	6	EA.	10" X 12-1/2" 11.04 - 11.44	
66	6	EA.	10" X 12-1/2" (w/tapped 3/4" cc outlet)	
67	6	EA.	10" X 12-1/2" (w/tapped 1" cc outlet)	
68	6	EA.	10" X 12-1/2" oversized 11.37 - 11.75	
69	6	EA.	10" X 20" Full Circle	
70	6	EA.	12" X 15" 13.20 - 13.50	

**PRICE SHEET ( PAGE 4 of 10)**

**Vendor Name:** \_\_\_\_\_

ITEM #	EST. QTY	UNIT	DESCRIPTION	UNIT PRICE
			<b>GATE VALVES - CUT - IN MJ X MJ TYPE RESILIENT SEAT (WITH ALL ACCESSORIES) BONNET STUFFING BOX AND RETAINING BOLTS, NUTS AND WASHERS TO BE STAINLESS STEEL; ALL CLOSE CLOCKWISE AWWA C509 MUELLER CO. OR EQUAL</b>	
71	6	EA.	4"	
72	6	EA.	6"	
73	6	EA.	8"	
74	4	EA.	10"	
			<b>BUTTERFLY VALVES - MJ X MJ (WITH ALL ACCESSORIES) ALL CLOSE CLOCKWISE - AWWA C504 - PRATT OR MUELLER</b>	
75	2	EA.	12"	
76	2	EA.	16"	
77	2	EA.	20"	
78	2	EA.	24"	
			<b>MECHANICAL JOINT ACCESSORIES PACKAGE TO INCLUDE: GLAND; RUBBER GASKET AND BOLT KITS MJ ENDS AND ACCESSORIES - ANSI/AWWA C111/21.11</b>	
79	12	EA.	4"	
80	12	EA.	6"	
81	12	EA.	8"	
82	12	EA.	10"	
83	12	EA.	12"	
84	12	EA.	16"	
			<b>MEGALUG RESTRAINTS SERIES 1100 TO INCLUDE: GLAND; RUBBER GASKET AND BOLT KITS</b>	
85	10	EA.	4"	
86	10	EA.	6"	
87	10	EA.	6" Series 1100X Oversize	
88	6	EA.	8"	
89	6	EA.	10"	
90	6	EA.	12"	
91	6	EA.	36"	

**PRICE SHEET ( PAGE 5 of 10)**

**Vendor Name:** \_\_\_\_\_

ITEM #	EST. QTY	UNIT	DESCRIPTION	UNIT PRICE
			<b>MEGALUG RESTRAINTS TO INCLUDE GLAND; RUBBER GASKET AND BOLT KITS</b>	
92	6	EA.	1116 Series, Ductile Iron, 16"	
93	6	EA.	1120 Series, Ductile Iron, 20"	
94	6	EA.	1124 Series, Ductile Iron, 24"	
			<b>PLASTIC/BRASS/COPPER SERVICE LINE MATERIALS BUSHINGS: (MUELLER (CC) THREAD) MUELLER H-10036, FORD BBAA SERIES OR EQUAL</b>	
95	12	EA.	1" cc X 3/4" cc	
96	12	EA.	1 1/2" cc X 3/4" cc	
97	12	EA.	1 1/2" cc X 1" cc	
98	6	EA.	2" cc X 3/4" cc	
99	6	EA.	2" cc X 1" cc	
100	6	EA.	2" cc X 1 1/2" cc	
			<b>PLUGS: THREAD AS INDICATED MUELLER H-1003X SERIES, FORD CSP SERIES OR EQUAL</b>	
101	10	EA.	1/2" IPT	
102	10	EA.	5/8" IPT	
103	8	EA.	3/4" cc	
104	4	EA.	3/4" IPT	
105	4	EA.	1" cc	
106	4	EA.	1" IPT	
107	4	EA.	1 1/2" cc	
108	4	EA.	1 1/2" IPT	
109	4	EA.	2" cc	
110	4	EA.	2" IPT	
			<b>LEAD PACK COMPRESSION COUPLINGS: LEAD ONE END/COPPER OTHER END - FORD NOS. &amp; SIZE (ALL ITEMS COMPLY WITH AWWA C-800-84)</b>	
111	35	EA.	Q28-33 3/4" strong to 3/4" IPT	
112	35	EA.	Q38-33 3/4" XXS to 3/4" IPT	
113	30	EA.	Q14-33 3/4" strong to 3/4" copper comp.	
114	35	EA.	Q24-33 3/4" XS to 3/4" copper comp.	
115	35	EA.	Q34-43 3/4" XXS to 3/4" copper	

**PRICE SHEET ( PAGE 6 of 10)**

**Vendor Name:** \_\_\_\_\_

ITEM #	EST. QTY	UNIT	DESCRIPTION	UNIT PRICE
			<b>LEAD PACK COMPRESSION COUPLINGS: LEAD ONE END/COPPER OTHER END - FORD NOS. &amp; SIZE ALL ITEMS COMPLY WITH AWWA C-800-84 (continued)</b>	
116	20	EA.	Q24-43 1" XS to 3/4" copper	
117	20	EA.	Q34-43 1" XXS to 3/4" copper	
118	14	EA.	Q14-44 1" strong to 1" copper	
119	6	EA.	Q24-44 1" XS to 1" copper	
120	12	EA.	Q34-44 1" XXS to 1" copper	
121	10	EA.	Q24-66 1 1/2" XS to 1 1/2" copper	
122	10	EA.	Q24-77 2" XS to 2" copper	
			<b>ADAPTERS – ALL COMPRESSION:</b>	
123	50	EA.	3/4" Male H-15-428	
124	50	EA.	3/4" Female H-15-451	
125	30	EA.	1" Male IPT to 1" Copper Compression	
126	30	EA.	1" Female IPT to 1" Copper Compression	
127	8	EA.	1 1/2" Male IPT to 1 1/2" Copper Compression	
128	8	EA.	1 1/2" Female IPT to 1 1/2" Copper Compression	
129	8	EA.	2" Female IPT H-15-451 to 2" Copper	
130	8	EA.	2" Male IPT H-15-428	
			<b>CORPORATION STOPS (Ford or Mueller Equivalent) FORD NOS. &amp; SIZE</b>	
131	12	EA.	F600-L04-33S 3/4" Copper Corp. w/swivel – 90 degree compression	
132	50	EA.	F600-L04-44S 1" Copper Corp. w/swivel – 90 degree compression	
133	12	EA.	F700-L0445 1" Iron pip w/swivel – 90 degree compression	
134	4	EA.	H-15-071-L04-66 1-1/2" Copper Corp. w/swivel – 90 degree compression	
135	4	EA.	H-15-071-L04-77 2" Copper Corp. w/swivel – 90 degree compression	
136	5	EA.	2" FB 800 AWWA Thread	
137	12	EA.	3/4" 90 Degree Angle Meter Coupling L-38-23	
138	10	EA.	1" 90 Degree Angle Meter Coupling L-38-44	
139	6	EA.	1" IPT Female Cap	
140	6	EA.	3/4" IPT Inlet w/1" Male IPT Outlet	

**PRICE SHEET ( PAGE 7 of 10)**

**Vendor Name:** \_\_\_\_\_

ITEM #	EST. QTY	UNIT	DESCRIPTION	UNIT PRICE
<b>COPPER TUBING - TYPE K</b>				
141	10	EA.	60 Foot Rolls - 3/4"	
142	5	EA.	60 Foot Rolls - 1"	
143	4	EA.	60 Foot Rolls - 1-1/2"	
144	4	EA.	60 Foot Rolls - 2"	
<b>CURB STOPS (Ford or Mueller Equivalent) FORD NOS. &amp; SIZE</b>				
145	16	EA.	B44-333 3/4" Copper	
146	25	EA.	B11-333 3/4" Reg. IPTHD	
147	8	EA.	B44-444 1" Copper	
148	8	EA.	B11-444 1" Reg IPTHD	
149	6	EA.	B44-666 1-1/2" Copper	
150	44	EA.	B44-777 2" Copper	
151	5	EA.	B11-777 2" Reg IPTHD	
152	20	EA.	Compression Coupling for 3/4" Copper to 3/4" Copper	
153	10	EA.	Compression Coupling 1" Copper to 1" Copper	
154	6	EA.	Compression Coupling 1-1/2" copper to 1-1/2" copper	
155	4	EA.	Compression Coupling 2" Copper to 2" Copper	
<b>MECHANICAL JOINTS, SHORT BODY (COMPACT) WITH FLUOROCARBON COATING</b>				
156	10	EA.	16"	
157	10	EA.	20"	
158	10	EA.	24"	
<b>HYMAX COUPLINGS</b>				
159	20	EA.	4"	
160	50	EA.	6"	
161	20	EA.	8"	
162	10	EA.	10"	
163	6	EA.	12"	
164	8	EA.	16" (860-56-0434-16P)	
165	6	EA.	20" (860-56-0540-16P)	
166	6	EA.	24" (860-56-0624-16P)	
167	2	EA.	36"	



**PRICE SHEET ( PAGE 9 of 10)**

**Vendor Name:** \_\_\_\_\_

ITEM #	EST. QTY	UNIT	DESCRIPTION	UNIT PRICE
<b>FERNCO COUPLINGS/ADAPTERS</b>				
177	10	EA.	36" Clay to Plastic	
178	10	EA.	36" Plastic to Plastic	
179	10	EA.	24" Clay to Plastic	
180	10	EA.	24" Plastic to Plastic	
181	10	EA.	20" Clay to Plastic	
182	10	EA.	20" Plastic to Plastic	
183	10	EA.	18" Clay to Plastic	
184	10	EA.	18" Plastic to Plastic	
185	6	EA.	15" Clay to Plastic	
186	6	EA.	15" Plastic to Plastic	
187	10	EA.	12" Clay to Plastic	
188	10	EA.	12" Plastic to Plastic	
189	20	EA.	10" Clay to Plastic	
190	20	EA.	10" Plastic to Plastic	
191	50	EA.	8" Clay to Plastic	
192	50	EA.	8" Plastic to Plastic	
193	30	EA.	6" Clay to Plastic	
194	30	EA.	6" Plastic to Plastic	
195	10	EA.	4" Clay to Plastic	
196	10	EA.	4" Plastic to Plastic	
<b>SEWER PIPE SDR 35 (PVC), PER FOOT OF LENGTH</b>				
197		FT.	36" Diameter	
198		FT.	30" Diameter	
199		FT.	24" Diameter	
200		FT.	20" Diameter	
201		FT.	18" Diameter	
202		FT.	15" Diameter	
203		FT.	12" Diameter	
204		FT.	10" Diameter	
205		FT.	8" Diameter	
206		FT.	6" Diameter	
207		FT.	4" Diameter	

**PRICE SHEET ( PAGE 10 of 10)**

**Vendor Name:** \_\_\_\_\_

ITEM #	EST. QTY	UNIT	DESCRIPTION	UNIT PRICE
			<b>DUCTILE IRON PIPE, PER FOOT OF LENGTH</b>	
208			18" Diameter	
209			15" Diameter	
210			12" Diameter	
211			10" Diameter	
212			8" Diameter	
213			6" Diameter	
214			4" Diameter	
215			4" Diameter	

NOTES:



# APPENDIX A

## **NFWB SEALED BID CONTRACT STANDARD TERMS, CONDITIONS, AND REQUIREMENTS**

**APPENDIX A**  
**NFWB SEALED BID CONTRACT**  
**STANDARD TERMS, CONDITIONS, AND REQUIREMENTS**

The parties to the attached contract or agreement (hereinafter “contract” or “agreement”) agree to be bound by the following clauses which are hereby made a part of the contract (the word “contractor” herein refers to any party to the contract other than the Niagara Falls Water Board). Any party submitting a bid in response to the attached solicitation also agrees to comply with these terms, conditions, and requirements.

**A. Statement of Qualifications**

OMITTED FOR THIS PROCUREMENT.

**B. Personnel**

OMITTED FOR THIS PROCUREMENT.

**C. Coordination and Cooperation with Third Parties**

OMITTED FOR THIS PROCUREMENT.

**D. Safety and Site-Specific Safety Plan**

OMITTED FOR THIS PROCUREMENT.

**E. Insurance**

Contractor shall be required to procure and maintain at its own expense and without expense to the Niagara Falls Water Board insurance for liability for damages imposed by law, of the kinds and amounts hereinafter provided, from insurance companies authorized to do business in the State of New York covering all operations under the contract, whether performed by the contractor or its subcontractors. Before proceeding with any work under the contract, the contractor shall furnish to the Niagara Falls Water Board Certificate of Insurance form(s) and relevant insurance policy declarations and endorsements satisfactory to the Water Board exhibiting compliance with this paragraph and providing that the policies shall not be changed or canceled until thirty (30) days written notice has been given to the Niagara Falls Water Board. The types and limits of insurance shall be as follows:

1. Workers Compensation as required by Law (submit Form C-105.2);
2. Disability Benefits as required by Law (submit Form DB-120.1);
3. Employer’s Liability with a minimum limit of \$100,000;
4. Commercial General Liability insurance: Bodily, Personal Injury, and Property Damage Liability limits each of at least \$1,000,000 per occurrence/\$2,000,000 aggregate, which shall include the following coverages:

- a. Owner’s Protective Liability
  - b. Premises – Operations
  - c. Broad Form Contractual
  - d. Independent Contractor and Sub-Contractor
  - e. Products and Completed Operations
5. Automobile Liability: \$1,000,000 single limit;
  6. Umbrella/Excess Liability: OMITTED FOR THIS PROCUREMENT
  7. Professional Liability/Errors and Omissions: OMITTED FOR THIS PROCUREMENT

Certificates, declarations, and endorsements should be made to the Niagara Falls Water Board, 5815 Buffalo Avenue, Niagara Falls, NY 14304.

The Niagara Falls Water Board, the Niagara Falls Public Water Authority, and the City of Niagara Falls, New York shall be named as an Additional Insureds, for both Ongoing and Completed Operations on a primary and non-contributory basis, on the Liability (General Liability, Auto Liability and Excess Liability ) Policies (except for professional liability) with the following provision: The insurance company or companies issuing the policies shall have no recourse against the Niagara Falls Water Board or the Niagara Falls Public Water Authority for payment of any premiums or for assessments under any form of policy.

In the event that the contractor requires any subcontractor to procure insurance with regard to any of the operations under the contract and requires such subcontractor to name the contractor as an additional insured under such insurance, the contractor shall ensure that such policy names the Water Board, Niagara Falls Public Water Authority, and their officers and employees as additional insureds.

**F. Indemnification and Waiver of Subrogation**

Contractor, to the full extent permissible by New York law, agrees to indemnify and hold the Niagara Falls Water Board, its Directors, Officers, and Employees harmless against all loss, cost, or damage, on account of injury to person or damage to property as a result of any action or inaction of the contractor or its representatives or agents or subcontractors in performance of the contract and against all fines, penalties any other losses which the Niagara Falls Water Board shall be obliged to pay or incur in connection with the performance of the work under the contract.

The contractor also must agree to waive all rights against the Water Board, including its officials and employees, for any damages or losses that are covered under any insurance required by this contract, or any other insurance applicable to the operations of the contractor and/or its subcontractors in the performance of the contract.

**G. Independent Contractor**

The contractor and its employees will operate as an independent contractor and are not considered Water Board employees.

**H. Identification of Subcontractors**

Contractor must identify its subcontractors, if any, in its bid, but award of a contract shall not create any relationship between the subcontractors and Water Board, and contractor shall be responsible for the entire contract. The Water Board shall have the right to reject any proposed subcontractors.

**I. Successors and Assigns**

The contract shall inure to the benefit of and be binding upon the legal representatives and successors of the parties, respectively, but contractor may not assign, transfer, convey, sub-let, or otherwise dispose of its rights, title, or interest in the contract without the Water Board's prior written consent. In the event that contractor assigns, transfers, conveys, sub-lets or otherwise disposes of any of its interest in the contract without the Water Board's prior written consent or purports to do so, the Water Board shall revoke and annul the contract and shall be relieved and discharged from any and all liability and obligations arising out of the contract and to contractor and to the person or corporation to which the contract shall have been assigned, transferred, conveyed, sublet or otherwise disposed of, and contractor, and his assignees, transferees or sublessees shall forfeit and lose all moneys, theretofore earned under the contract, except so much as may be required to pay contractor's employees for work performed under the contract. The provisions of this section shall not hinder, prevent, or affect an assignment by contractor for the benefit of his creditors made pursuant to New York State law.

**J. No Third Party Rights**

Nothing in this contract shall be construed or deemed to create any right in any person or entity not a party to the contract, except any permitted successors and assigns, and nothing in this contract shall be construed in any way to be a contract in whole or in part for the benefit of any third party.

**K. Exemption from Tax**

Invoices and bills to the Water Board shall not include charges for any Federal, State or local excise, sales, transportation, or other tax, unless Federal or State law specifically levies such tax on purchases made by the Water Board.

**L. Set-Off Rights**

The Water Board shall have all of its common law, equitable and statutory rights of set-off. These rights shall include, but not be limited to, the Water Board's option to withhold for the purposes of set-off any moneys due to the contractor under this contract up to any amounts due and owing from contractor to the Water Board with regard to this contract, any other contract with the Water Board, including any contract for a term commencing prior to the term of this contract, plus any amounts due and owing from contractor to the Water Board for any other reason including, without limitation, any monetary penalties.

**M. Records.**

The contractor shall establish and maintain complete and accurate books, records, documents, accounts and other evidence directly pertinent to performance under this contract (hereinafter, collectively, "the Records"). The Records must be kept for the balance of the calendar year in which they were made and for six (6) additional years thereafter. The State Comptroller, the Attorney General and

any other person or entity authorized to conduct an examination, as well as the Water Board and its representatives, shall have access to the Records during normal business hours at an office of the contractor within the State of New York or, if no such office is available, at a mutually agreeable and reasonable venue within the State, for the term specified above for the purposes of inspection, auditing and copying. The Water Board shall take reasonable steps to protect from public disclosure any of the Records which are exempt from disclosure under Section 87 of the Public Officers Law (the "Statute") provided that: (i) the Contractor shall timely inform an appropriate Water Board official, in writing, that said Records should not be disclosed; and (ii) said Records shall be sufficiently identified; and (iii) designation of said Records as exempt under the Statute is reasonable. Nothing contained herein shall diminish, or in any way adversely affect, the Water Board's right to discovery in any pending or future litigation.

**N. Freedom of Information Law – Claim of Confidential, Proprietary, or Trade Secret Information**

The Water Board is subject to the provisions of the Freedom of Information Law ("FOIL"), N.Y. Public Officers Law, Sections 84 through 90, relating to public access to agency records. The contractor shall specifically identify any portions of the documents submitted with the bid or proposal deemed to be confidential, proprietary information, or trade secrets and provide any justification why such material, upon request, should not be disclosed by the Water Board. The top of each page containing such information must be clearly marked in bold type "**PROPOSER BELIEVES THAT THIS INFORMATION IS PROTECTED FROM DISCLOSURE UNDER THE STATE FREEDOM OF INFORMATION LAW.**" Such information deemed by the contractor to be confidential/proprietary shall be easily separable from the non-confidential/non-proprietary sections of the bid or proposal.

The Water Board accepts no responsibility for disclosure of information designated as exempt from disclosure, but the Board does intend to evaluate, on a case-by-case basis, whether exemption from disclosure applies when a FOIL request is made to the Water Board for examination of such a document. Contractors should be aware that any and all terms of their respective proposals or bids may be the subject of discussion at Board of Directors meetings that are open to the public.

**O. Compliance with Breach Notification and Data Security Laws**

Contractor shall comply with the provisions of the New York State Information Security Breach and Notification laws, General Business Law §§ 899-aa and 899-bb and State Technology Law § 208.

**P. General Conditions of Bids**

Detailed instructions regarding the submission of bids are set forth in the contract documents. In all cases, the Water Board shall have the right to reject all bids or to waive any technical defect, qualification, omission, informality, or irregularity in any bid received.

**Q. Bids Firm and Irrevocable for 60 Days**

The Water Board reserves the right to make awards within 60 calendar days after the time designated herein for the opening of bids, during which 60 days, bids may not be withdrawn.

## **R. Conflicting Terms**

In the event of a conflict between the terms of the contract (including any and all attachments thereto and amendments thereof) and the terms of this Exhibit A, the terms of this Exhibit A shall control.

## **S. Addenda**

Any clarification, interpretation, correction, or change of the bidding documents will be made by written addendum. Clarifications, interpretations, corrections, or changes of the bidding documents made in any other manner will not be binding, and contractors shall not rely upon such clarifications, interpretations, corrections, or changes. Contractors shall acknowledge the number of addenda received using this Appendix's Form No. 1.

## **T. Non-Discrimination and Prohibition Against Sexual Harassment**

In accordance with Article 15 of the Executive Law (also known as the Human Rights Law) and all other State and Federal statutory and constitutional nondiscrimination provisions, the contractor will not discriminate against any employee or applicant for employment because of race, creed, color, sex (including gender identity or expression), sexual orientation, national origin, age, disability, military status, predisposing genetic characteristics, domestic violence victim status, or marital status. Furthermore, in accordance with Section 220-e of the Labor Law, if this is a contract for the construction, alteration, and/or repair of any public building and/or public work and/or for the manufacture, sale, and/or distribution of materials, equipment, and/or supplies, and to the extent that the contract shall be performed within the State of New York, contractor agrees that neither it nor its subcontractors shall, by reason of race, creed, color, disability, sex, or national origin: (a) discriminate in hiring against any New York State citizen who is qualified and available to perform the work; and/or (b) discriminate against or intimidate any employee hired for the performance of work under the contract. If this is a building service contract as defined in Section 230 of the Labor Law, then, in accordance with Section 239 thereof, contractor agrees that neither it nor its subcontractors shall by reason of race, creed, color, national origin, age, sex or disability: (a) discriminate in hiring against any New York State citizen who is qualified and available to perform the work; or (b) discriminate against or intimidate any employee hired for the performance of work under this contract. Contractor is subject to fines of \$50.00 per person per day for any violation of Section 220-e or Section 239 as well as possible termination of this contract and forfeiture of all moneys due hereunder for a second or subsequent violation.

Contractor agrees that prior to the award of a contract, it shall submit an Equal Employment Opportunity ("EEO") Policy Statement to the Water Board containing at a minimum the terms therefore as set forth in this Appendix's Form No. 4.

By submission of a bid, contractor and each person signing on behalf of contractor certifies, and in the case of a joint bid each party thereto certifies as to its own organization, under penalty of perjury, that the contractor has and has implemented a written policy addressing sexual harassment prevention in the workplace and provides annual sexual harassment prevention training to all of its employees. Such policy shall, at a minimum, meet the requirements of section two hundred one-g of the

labor law. Contractor agrees that prior to the award of a contract, it shall submit the Statement on Sexual Harassment form at this Appendix's Form No. 5.

#### **U. Iranian Energy Sector Divestment**

Pursuant to Public Authorities Law § 2879-c, by signing this contract, each person and each person signing on behalf of any other party certifies, and in the case of a joint bid or partnership each party thereto certifies as to its own organization, under penalty of perjury, that to the best of its knowledge and belief that each person is not on the list created pursuant to paragraph (b) of subdivision 3 of section 165-a of the state finance law. This list of persons who engage in investment activities in Iran is available at: <http://www.ogs.ny.gov/about/regs/docs/ListofEntities.pdf>.

#### **V. International Boycott Prohibition**

In accordance with Section 220-f of the Labor Law and Section 139-h of the State Finance Law, if this contract exceeds \$5,000, the contractor agrees, as a material condition of the contract, that neither the contractor nor any substantially owned or affiliated person, firm, partnership or corporation has participated, is participating, or shall participate in an international boycott in violation of the federal Export Administration Act of 1979 (50 USC App. Sections 2401 *et seq.*) or regulations thereunder. If such contractor, or any of the aforesaid affiliates of contractor, is convicted or is otherwise found to have violated said laws or regulations upon the final determination of the United States Commerce Department or any other appropriate agency of the United States subsequent to the contract's execution, such contract, amendment or modification thereto shall be rendered forfeit and void. The Contractor shall so notify the State Comptroller within five (5) business days of such conviction, determination or disposition of appeal (2 NYCRR 105.4).

#### **W. MacBride Fair Employment Principles**

In accordance with the MacBride Fair Employment Principles (Chapter 807 of the Laws of 1992), the contractor hereby stipulates that contractor and any individual or legal entity in which the contractor holds a ten percent or greater ownership interest and any individual or legal entity that holds a ten percent or greater ownership interest in the contractor either (a) have no business operations in Northern Ireland, or (b) shall take lawful steps in good faith to conduct any business operations in Northern Ireland in accordance with the MacBride Fair Employment Principles (as described in Section 165(5) of the State Finance Law), and shall permit independent monitoring of compliance with such principles.

#### **X. Prohibition on Purchase of Tropical Hardwoods**

The contractor certifies and warrants that all wood products to be used under this contract award will be in accordance with, but not limited to, the specifications and provisions of State Finance Law §165 (Use of Tropical Hardwoods) which prohibits purchase and use of tropical hardwoods, unless specifically exempted, by the State or any governmental agency or political subdivision or public benefit corporation. Qualification for an exemption under this law will be the responsibility of the contractor to establish to meet with the approval of the State.

In addition, when any portion of this contract involving the use of woods, whether supply or installation, is to be performed by any subcontractor, the prime contractor will indicate and certify in the submitted bid that the subcontractor has been informed and is in compliance with specifications and provisions regarding use of tropical hardwoods as detailed in §165 State Finance Law. Any such use must meet with the approval of the State, otherwise, the bid may not be considered responsive. Proof of qualification for exemption will be the responsibility of the Contractor to meet with the approval of the State.

**Y. Steel Products**

If this contract involves steel products, then pursuant to Public Authorities Law § 2601-a:

- a. All purchase contracts for supplies, material or equipment involving an estimated expenditure in excess of fifty thousand dollars shall require with respect to materials, supplies and equipment made of, fabricated from, or containing steel components, that such steel components be produced or made in whole or substantial part in the United States, its territories or possessions.
- b. All contracts in excess of one hundred thousand dollars for the construction, reconstruction, alteration, repair, maintenance or improvement of public works shall require that all structural steel, reinforcing steel or other major steel items to be incorporated in the work of the contract shall be produced or made in whole or substantial part in the United States, its territories or possessions.

**Z. Delivery of Products**

Products to be delivered by contractor to the Water Board shall be delivered FOB destination, prepaid and invoiced.

**AA. Wage and Hour Requirements**

OMITTED FOR THIS CONTRACT.

**BB. Workforce Reporting**

OMITTED FOR THIS CONTRACT.

**CC. M/WBE and SDVOB Requirements and Grant Funded Projects**

OMITTED FOR THIS CONTRACT.

**DD. New York State Certified Apprenticeship Training Program Requirements**

OMITTED FOR THIS CONTRACT.

**EE. Payment**



Contractor agrees to provide complete and accurate billing invoices to the Water Board on a monthly basis, and will comply with cover sheet requirements or other invoice submission procedures as the Water Board may from time to time require. Invoices submitted must contain sufficient information and documentation to support the charges submitted. Documentation may include time sheets, expense vouchers and any other supportive documentation requested by the Water Board or its representative. If contractor is in compliance with applicable prevailing wage laws and has satisfactorily completed all required Minority, Women, and Disadvantaged Business Enterprise and Service-Disabled Veteran-Owned Business utilization and reporting requirements, payment shall be made monthly on the basis of invoices submitted by contractor, each payment to be due sixty (60) days after receipt of the invoice, unless the Water Board reasonably disputes some or all of the invoice.

**FF. Conflicts of Interest and Prohibition on Political and Religious Activity**

By submitting a bid or by assuming the responsibility of a contract awarded hereunder, contractor stipulates that, upon information and belief, no member of the governing body of the Water Board, or officer or employee of the Water Board, forbidden by Law, is interested in, will derive benefit from, or will be a party to, the contract between contractor and the Water Board. Contractor warrants that no payment, gift, or thing of value has been or will be made, given, or promised any Director, Officer, or Employee of the Water Board, or any member of the immediate family of any Director, Officer, or Employee of the Water Board (spouse, parent, sister, brother, or child) to obtain this or any other agreement between the parties. Contractor agrees that its provision of services under this contract shall not include any partisan political activity or any activity to further the election or defeat of any candidate for public, political, or party office, nor shall any of the funds provided under the contract be used for such purposes. The contractor further agrees that there shall be no religious worship, instruction, or proselytizing as part of or in connection with the contractor's provision of services under the contract, nor shall any of the funds provided under this agreement be used for such purposes.

**GG. Non-Collusion**

Contractor must submit a signed non-collusive bidding certification on the form that is this Appendix's Form No. 2.

**HH. Communication with Water Board and Lobbying Law.**

Bidders/contractors are advised that, from the date the notice to bidders or invitation to bid is issued until the award of the contract, no contact by bidders or their agents with the Water Board or Water Board personnel related to this procurement is permitted, except as shall be authorized by the authorized Water Board contact indicated on the invitation to bid.

Pursuant to State Finance Law Sections 139-j and 139-k, this solicitation includes and imposes certain restrictions on communication between respondents and the Water Board during the procurement process. A respondent is restricted from making contacts from the date the invitation to bid is issued through the final contract award by Water Board (the "Restricted Period"). During the Restricted Period, respondents may only contact the designated contact regarding this procurement. The

designated contact is identified on the invitation to bid or notice to bidders. Respondents are responsible for complying with State Finance Law Sections 139-j and 139-k. Directors, officers and employees of the Water Board are required to record certain information when contacted during the Restricted Period. A review of whether such contacts were permissible contacts will be considered in connection with any determination of responsibility of the respondent. Failure of any respondent to timely certify or to disclose accurate and complete information or the submission of any intentionally false or intentionally incomplete certification may result in the rejection of the contract award or if such contract has been executed, then the immediate termination of the contract. Violations may result in debarment of the respondent from proposing on or obtaining governmental procurement contracts in the State of New York.

Contractors are required to complete and return with their bid this Appendix's Form No. 3, New York State Finance Law Sections 139-j and 139-k ("Lobbying Law") — Disclosure Statement.

## **II. Waiver of Immunity**

By entering into this agreement, the contractor agrees, acknowledges, and accepts that pursuant to Public Authorities Law § 2875, upon the refusal by a person, when called before a grand jury, head of a state department, temporary state commission or other state agency, the organized crime task force in the department of law, head of a city department, or other city agency, which is empowered to compel the attendance of witnesses and examine them under oath, to testify in an investigation concerning any transaction or contract had with the state, any political subdivision thereof, a public authority or with any public department, agency or official of the state or of any political subdivision thereof or of a public authority, to sign a waiver of immunity against subsequent criminal prosecution or to answer any relevant question concerning such transaction or contract, (a) such person, and any firm, partnership or corporation of which he is a member, partner, director or officer shall be disqualified from thereafter selling to or submitting bids to or receiving awards from or entering into any contracts with any public authority or official thereof, for goods, work or services, for a period of five years after such refusal, and (b) any and all contracts made with any public authority or official thereof, by such person and by any firm, partnership or corporation of which he is a member, partner, director or officer may be cancelled or terminated by the public authority without incurring any penalty or damages on account of such cancellation or termination, but any monies owing by the public authority for goods delivered or work done prior to the cancellation or termination shall be paid.

## **JJ. Termination**

1. For Cause: For a material breach that remains uncured for more than thirty (30) days or other specified period after written notice to the contractor, the contract may be terminated by the Water Board at the contractor's expense where contractor becomes unable or incapable of performing, or meeting any requirements or qualifications set forth in the contract, or for nonperformance, or upon a determination that contractor is nonresponsible. Such termination shall be upon written notice to the contractor. In such event, the Water Board may complete the contractual requirements in any manner it may deem advisable and pursue available legal or equitable remedies for breach.

2. For Convenience: By written notice, this contract may be terminated at any time by the Water Board for convenience upon thirty (30) days written notice and without penalty or other early termination charges due. Such termination of the contract shall not affect contractor's right to recover for any work performed or materials acquired under the contract prior to the date of such termination, provided that contractor cancels, prior to the effective date of the termination, as many outstanding obligations as possible and agrees not to incur any new obligations after receipt of the notice of termination without approval by the Water Board. If the contract is terminated pursuant to this subdivision, the Water Board shall remain liable for all accrued but unpaid charges incurred through the date of the termination. Contractor shall use due diligence and provide any outstanding deliverables.
3. For Violation of the Sections 139-j and 139-k of the State Finance Law: The Water Board reserves the right to terminate the contract in the event it is found that the certification filed by the contractor in accordance with Section 139-k of the State Finance Law was intentionally false or intentionally incomplete. Upon such finding, the Water Board may exercise its termination right by providing written notification to the contractor.

#### **KK. Governing Law and Venue**

These terms and conditions and the contract shall be governed by the laws of the State of New York. Each of the parties to these terms and conditions and the contract submits to the exclusive jurisdiction and venue of the State and Federal courts located in Niagara County, New York, or if the required Federal courts are not located in Niagara County, to the Federal courts located in Erie County, New York.

#### **LL. Service of Process and Notices**

In addition to the methods of service allowed by the State Civil Practice Law & Rules ("CPLR"), contractor hereby consents to service of process upon it by registered or certified mail, return receipt requested. Service hereunder shall be complete upon contractor's actual receipt of process or upon the Water Board's receipt of the return thereof by the United States Postal Service as refused or undeliverable. Contractor must promptly notify the Water Board, in writing, of each and every change of address to which service of process can be made. Service by the Water Board to the last known address shall be sufficient. Contractor will have thirty (30) calendar days after service hereunder is complete in which to respond. A copy of all notices to the Water Board shall be provided to: Legal Department, Niagara Fall Water Board, 5815 Buffalo Avenue, Niagara Falls, NY 14304.

#### **MM. No Waiver of Rights**

No failure or delay (in whole or in part) on the part of either party hereto to exercise any right or remedy hereunder shall impair its ability to later exercise any such right or remedy, operate as a waiver thereof, or affect any other rights or remedies that may be available under the law or in equity, except to the extent it causes actual prejudice to the other party. No waiver by either party of any covenant, condition, term or provision of the contract shall be deemed to have been made by that party unless such waiver is in writing and signed by an authorized representative of the party.

**APPENDIX A, FORM No. 1**

**ACKNOWLEDGEMENT OF ADDENDA**

PROJECT TITLE: \_\_\_\_\_  
(Write the Project No. and Title on the Line Above)

DIRECTIONS: Complete Part I or Part II, whichever is applicable.

PART I: LISTED BELOW ARE THE DATES OF ISSUE FOR EACH  
ADDENDUM RECEIVED IN CONNECTION WITH THIS BID:

ADDENDUM # 1: DATED \_\_\_\_\_ , 20\_\_

ADDENDUM # 2: DATED \_\_\_\_\_ , 20\_\_

ADDENDUM # 3: DATED \_\_\_\_\_ , 20\_\_

ADDENDUM # 4: DATED \_\_\_\_\_ , 20\_\_

ADDENDUM # 5: DATED \_\_\_\_\_ , 20\_\_

ADDENDUM # 6: DATED \_\_\_\_\_ , 20\_\_

PART II: \_\_\_\_\_ INITIAL HERE IF NO ADDENDUM WAS RECEIVED  
IN CONNECTION WITH THIS BID INITIAL HERE

DATE: \_\_/\_\_/\_\_\_\_

CONTRACTOR (SIGNATURE): \_\_\_\_\_

CONTRACTOR (NAME): \_\_\_\_\_

CONTRACTOR (FIRM): \_\_\_\_\_



**APPENDIX A, FORM No. 3****NEW YORK STATE FINANCE LAW SECTIONS 139-j AND 139-k  
(“LOBBYING LAW”) – DISCLOSURE STATEMENT****General Information**

All procurements by the Niagara Falls Water Board (“NFWB”) in excess of \$15,000 annually, are subject to New York State’s State Finance Law Sections 139-j and 139-k, effective January 1, 2006 (“Lobbying Law”).

Pursuant to the Lobbying Law, all “contacts” (defined as oral, written or electronic communications with the NFWB intended to influence a procurement) during a procurement - from the earliest notice of intent to solicit bids/proposals through final award and approval - must be made with one or more designated Point(s) of Contact only. Exceptions to this rule include written questions during the bid/proposal process, communications with regard to protests, contract negotiations, and pre-bid conference participation. Nothing in the Lobbying Law inhibits any rights to make an appeal, protest, or complaint under existing administrative or judicial procedures.

Violations of the policy regarding permissible contacts must be reported to the appropriate NFWB officer and investigated accordingly. The first violation may result in a determination of non-responsibility and ineligibility for award to the violator and its subsidiaries, affiliates and related entities. The penalty for a second violation within four (4) years is ineligibility for bidding/proposing on a procurement and/or ineligibility from being awarded any contract for a period of four (4) years. The NFWB will notify the New York State Office of General Services (“OGS”) of any determinations of non-responsibility or debarments due to violations of the Lobbying Law. Violations found to be “knowing and willful” must be reported to the NFWB Executive Director and OGS.

Moreover, the statutes require the NFWB to obtain certain affirmations and certifications from bidders and proposers. This Disclosure Statement contains the forms with which offerors are required to comply, together with additional information and instructions.

**Instructions**

New York State Finance Law §139-k(2) obligates the NFWB to obtain specific information regarding prior non-responsibility determinations. In accordance with New York State Finance Law §139-k, an offerer must be asked to disclose whether there has been a finding of non-responsibility made within the previous four (4) years by any governmental entity due to: (a) a violation of New York State Finance Law §139-j or (b) the intentional provision of false or incomplete information to a governmental entity.

As part of its responsibility determination, New York State Finance Law §139-k(3) mandates consideration of whether an offerer fails to timely disclose accurate or complete information regarding the above non-responsibility determination. In accordance with law, no procurement contract shall be awarded to any offerer that fails to timely disclose accurate or complete information under this section, unless the factual elements of the limited waiver provision can be satisfied on the written record.

**Disclosure of Prior Non-Responsibility Determinations**

**Name of Bidder/Proposer:** \_\_\_\_\_

**Address:** \_\_\_\_\_

**Name and Title of Person**

**Submitting this Form:** \_\_\_\_\_

**Has any governmental entity<sup>1</sup> made a finding of non-responsibility regarding the Bidder/Proposer in the previous four years?**

\_\_\_ Yes \_\_\_ No

**If yes: Was the basis for the finding of the Bidder's/Proposer's non-responsibility due to a violation of State Finance Law §139-j?**

\_\_\_ Yes \_\_\_ No

**Was the basis for the finding of Bidder's/Proposer's non-responsibility due to the intentional provision of false or incomplete information to a governmental entity?**

\_\_\_ Yes \_\_\_ No

**If yes to any of the above questions, provide details regarding the finding of non-responsibility below:**

Governmental Entity: \_\_\_\_\_

Year of Finding of Non-responsibility: \_\_\_\_\_

Basis of Finding of Non-Responsibility (attach additional pages if necessary): \_\_\_\_\_

---



---



---



---



---



---



---



---



---



---





**NOTICE OF NFWB'S RIGHT TO TERMINATE**

The NFWB reserves the right to terminate a Contract (including any lease, license, entry permit, or sale documents) in the event it is found that the certification filed by the Bidder/Proposer, in accordance with New York State Finance Law §139-k, was intentionally false or intentionally incomplete. Upon such finding, the NFWB may exercise its termination right by providing written notification to the Bidder/Proposer in accordance with the written notification terms of the Contract.

**Bidder or Proposer's Affirmation and Certification**

By signing below, the Bidder or Proposer:

- a) Affirms that the Bidder or Proposer understands and agrees to comply with the policy regarding permissible contacts in accordance with New York State Finance Law Sections 139-j and 139-k.
- b) Certifies that all information provided to the NFWB with respect to New York State Finance Law §139-j and §139-k is complete, true and accurate.

DATE: \_\_\_/\_\_\_/\_\_\_

BIDDER/PROPOSER (SIGNATURE): \_\_\_\_\_

BIDDER/PROPOSER (NAME): \_\_\_\_\_

BIDDER/PROPOSER (FIRM): \_\_\_\_\_

STATE OF \_\_\_\_\_ )  
 ) ss.:  
COUNTY OF \_\_\_\_\_ )

On the \_\_\_ day of \_\_\_\_\_, 20\_\_\_, before me, the undersigned, a Notary Public in and for said state, personally appeared \_\_\_\_\_ as a representative of \_\_\_\_\_, personally known to me or proved to me on the basis of satisfactory evidence to be the individual whose name is subscribed to the within instrument and acknowledged to me that he/she executed the same in his/her capacity, and that by his/her signature on the instrument, the entity on behalf of which the individual acted executed the instrument.

\_\_\_\_\_  
Notary Public

**APPENDIX A, FORM No. 4**

**EQUAL EMPLOYMENT OPPORTUNITY (“EEO”)  
POLICY STATEMENT AND AGREEMENT**

Contractor hereby agrees to the following EEO policy with respect to its work on any contract awarded in connection with this procurement:

- a) This organization will not discriminate against any employee or applicant for employment because of race, creed, color, national origin, sex, age, disability or marital status, will undertake or continue existing programs of affirmative action to ensure that minority group members are afforded equal employment opportunities without discrimination, and shall make and document its conscientious and active efforts to employ and utilize minority group members and women in its work force on Niagara Falls Water Board (“Water Board”) contracts.
- b) This organization shall state in all solicitations or advertisements for employees that in the performance of the Water Board contract all qualified applicants will be afforded equal employment opportunities without discrimination because of race, creed, color, national origin, sex, disability or marital status.
- c) At the request of the Water Board, this organization shall request each employment agency, labor union, or authorized representative of workers with which it has a collective bargaining or other agreement or understanding, to furnish a written statement that such employment agency, labor union, or representative will not discriminate on the basis of race, creed, color, national origin, sex, age, disability or marital status and that such union or representative will affirmatively cooperate in the implementation of this organization’s obligations herein.
- d) This organization shall comply with the provisions of the Human Rights Law, all other State and Federal statutory and constitutional non-discrimination provisions. Contractor and its subcontractors shall not discriminate against any employee or applicant for employment because of race, creed (religion), color, sex, national origin, sexual orientation, pregnancy or pregnancy-related conditions, gender identity, familial status, military status, age, disability, predisposing genetic characteristic, marital status or domestic violence victim status, and shall also follow the requirements of the Human Rights Law with regard to non-discrimination on the basis of prior criminal conviction and prior arrest.
- e) This organization will include the provisions of section (a) through (d) of this agreement in every subcontract in such a manner that the requirements of the subdivisions will be binding upon each subcontractor as to work in connection with the Water Board contract.

**ACCEPTED AND AGREED:**

DATE: \_\_\_/\_\_\_/\_\_\_\_\_

CONTRACTOR (SIGNATURE):

\_\_\_\_\_

CONTRACTOR (NAME):

\_\_\_\_\_

CONTRACTOR (FIRM):

\_\_\_\_\_



APPENDIX A, FORM No. 6

STANDARD TERMS AND CONDITIONS
ACKNOWLEDGEMENT AND CERTIFICATION

As a duly-authorized representative of the contractor indicated below, I hereby acknowledge that by submitting a bid or proposal in connection with

(write Bid or Project Number and Title)

contractor has made a firm offer and agrees to be bound by its terms. Contractor has carefully read the contract, terms and conditions, bidding documents, and all addenda, and in submitting this bid or proposal acknowledges contractor understands and agrees to be bound by the requirements set forth in those documents.

I recognize that all information submitted is for the express purpose of inducing the Water Board to enter a contract with the submitting business entity. I affirm, under the penalties of perjury, that to the best of my knowledge the information contained in the bid or proposal is full, complete, and truthful.

DATE: \_\_/\_\_/\_\_

CONTRACTOR (SIGNATURE):

CONTRACTOR (NAME):

CONTRACTOR (FIRM):

STATE OF \_\_\_\_\_ )
) ss.:
COUNTY OF \_\_\_\_\_ )

On the \_\_\_ day of \_\_\_\_\_, 20\_\_, before me, the undersigned, a Notary Public in and for said state, personally appeared \_\_\_\_\_ as a representative of \_\_\_\_\_, personally known to me or proved to me on the basis of satisfactory evidence to be the individual whose name is subscribed to the within instrument and acknowledged to me that he/she executed the same in his/her capacity, and that by his/her signature on the instrument, the entity on behalf of which the individual acted executed the instrument.

Notary Public

**THIS PAGE INTENTIONALLY LEFT BLANK**

# APPENDIX B

## CITY OF NIAGARA FALLS

**VENDOR'S CERTIFICATION & ASSIGNMENT OF CLAIM**

**AFFIDAVIT OF NON-COLLUSIVE SUBMISSION CERTIFICATION**

**CERTIFICATION OF COMPLIANCE WITH THE IRAN  
DIVESTMENT ACT**

**NON-SUBMISSION CERTIFICATE**

**VENDOR'S CERTIFICATION & ASSIGNMENT OF CLAIM**

THIS FORM MUST BE COMPLETED IN INK, BE TYPED OR BE COMPUTER GENERATED, BE CLEARLY LEGIBLE AND BE SIGNED AND DATED WITH EITHER BLUE OR BLACK INK. FAILURE TO DO THIS MAY RESULT IN REJECTION.

I/We, the undersigned, herewith propose and agree to furnish to the City any one or all of the items upon which we have submitted, for the prices indicated herein, in accordance with the instructions, General Conditions and Specific Terms, Conditions and Specifications and any other related formal documents.

The undersigned individual certifies to having read these Instructions, General Conditions, Specific Terms, Conditions and Specifications and any other related formal documents and offers to furnish the articles specified to the City in exact accordance with same at the prices herein stated.

Vendor hereby assigns to the City and the State of New York any and all of its claim(s) for overcharges associated with this contract/agreement which arise under the antitrust laws of the United States, 15 U.S.C. Section 1, et seq. and the antitrust laws of the State of New York, G.B.L. Section 340, et seq.

\_\_\_\_\_  
VENDOR NAME

\_\_\_\_\_  
ADDRESS

\_\_\_\_\_  
CITY, STATE, ZIP

\_\_\_\_\_  
TELEPHONE NUMBER

\_\_\_\_\_  
EMAIL ADDRESS

\_\_\_\_\_  
NAME & TITLE OF AUTHORIZED CONTACT

\_\_\_\_\_  
AUTHORIZED SIGNATURE

\_\_\_\_\_  
DATE

**AFFIDAVIT OF NON-COLLUSIVE SUBMISSION CERTIFICATION**

I hereby attest and certify that I am the person responsible within my firm for the final decision as to price(s) and amount of this submission, or, if not, that I have written authorization, enclosed herewith, from that person to make the statements set out below on his or her behalf and on behalf of my firm. I further attest and certify that:

- 1. The price(s) and amount(s) of this submission have been arrived at independently, without consultation, communication or agreement for the purpose of restricting competition with any other contractor, vendor, bidder, or potential bidder.
- 2. Neither the price(s) nor the amount(s) of this submission have been disclosed to any other vendor, firm or person who is submitting or potentially submitting on this project, and will not so be disclosed prior to submission opening.
- 3. No attempt has been made or will be made to solicit, cause or induce any vendor, firm or person to refrain from submitting on this project, or to submit a higher price than the submission of this firm, or any intentionally high or non-competitive submission or other form of complementary submission.
- 4. The submission of my firm is made in good faith and not pursuant to any agreement or discussion with, or inducement from, any vendor, firm or person to submit a complementary submission.
- 5. My firm has not offered or entered into a subcontract or agreement regarding the purchase of materials or services from any vendor, firm or person, or offered, promised or paid cash or anything of value to any vendor, firm or person, whether in connection with this or any other project in consideration for an agreement or promise by any vendor, firm or person to refrain from submitting or to submit a complementary submission on this project.
- 6. My firm has not accepted or been promised any subcontract or agreement regarding the sale of materials or services to any vendor, firm or person, and has not been promised or paid cash or anything of value by any vendor, firm or person, whether in connection with this or any other project, in consideration for my firm's submitting a complementary submission, or agreeing to do so, on this project.
- 7. I have made a diligent inquiry of all members, officers, employees and agents of my firm with responsibilities relating to the preparation, approval or submission of my firm's submission on this project and have been advised by each of them that he or she has not participated in any communication, consultation, discussion, agreement, collusion, act or other conduct inconsistent with any of the statements and representations made.

**SUBMISSION IS NOT ACCEPTABLE WITHOUT THE ABOVE AFFIDAVIT  
SIGNED AND CERTIFIED BY A NOTARY PUBLIC**

\_\_\_\_\_  
VENDOR NAME

\_\_\_\_\_  
ADDRESS

\_\_\_\_\_  
CITY, STATE, ZIP

\_\_\_\_\_  
TELEPHONE NUMBER

\_\_\_\_\_  
NAME & TITLE

\_\_\_\_\_  
AUTHORIZED SIGNATURE

Sworn to before me this \_\_\_\_ day  
of \_\_\_\_\_, 20\_\_

\_\_\_\_\_  
Notary Public



**CERTIFICATION OF COMPLIANCE WITH THE IRAN DIVESTMENT ACT**

As a result of the Iran Divestment Act of 2012 (the "Act"), Chapter 1 of the 2012 Laws of New York, a new provision has been added to State Finance Law (SFL) § 165-a and New York General Municipal Law § 103-g. both effective April 12, 2012. Under the Act, the Commissioner of the office of General Services (OGS) will be developing a list of "persons" who are engaged in "investment activities in Iran" (both are defined terms in the law) (the "Prohibited Entities List"). Pursuant to SFL § 165-a(3)(b), the initial list is expected to be issued no later than 120 days after the Act's effective date at which time it will be posted on the OGS website.

By making a submission in response to this offering or by assuming the responsibility of an contract/agreement hereunder, each Vendor/Bidder/Contractor, any person signing on behalf of any Vendor/Bidder/Contractor and any assignee or subcontractor and, in the case of a joint bid, each party thereto, certifies, under penalty of perjury, that once the Prohibited Entities List is posted on the OGS website that to the best of its knowledge and belief that each Vendor/Bidder/Contractor and any subcontractor or assignee is not identified on the Prohibited Entities List created pursuant to SFL § 165-a(3)(b).

Additionally, Vendor/Bidder/Contractor is advised that once the Prohibited Entities List is posted on the OGS Website, any Vendor/Bidder/Contractor seeking to renew or extend a Contract or assume the responsibility of a Contract awarded in response to this offering must certify at the time the Contract is renewed, extended or assigned that it is not included on the Prohibited Entities List.

During the term of the agreement or contract, should the City receive information that a Vendor/Bidder/Contractor is in violation of the above-referenced certification, the City will offer the person, vendor or entity an opportunity to respond. If the person, vendor or entity fails to demonstrate that he/she/it has ceased engagement in the investment which is in violation of the Act within 90 days after the determination of such violation, then the City shall take such action as may be appropriate including, but not limited to, imposing sanctions, seeking compliance, recovering damages or declaring the Vendor/Bidder/Contractor in default.

The City reserves the right to reject any bid or request for assignment for a Vendor/Bidder/Contractor that appears on the Prohibited Entities List prior to the award of a contract and to pursue a responsibility review with respect to any Vendor/Bidder/Contractor that is awarded a contract and subsequently appears on the Prohibited Entities List.

I, \_\_\_\_\_, being duly sworn, depose and say that I am the \_\_\_\_\_ of \_\_\_\_\_, the vendor making this submission and that neither Vendor/Bidder/Contractor nor any proposed subcontractor is identified on the Prohibited Entities List.

\_\_\_\_\_  
Authorized Signature

Sworn to before me this \_\_\_\_ day  
of \_\_\_\_\_, 20\_\_

\_\_\_\_\_  
Notary Public

**NON-SUBMISSION CERTIFICATE**

1. Place an X on the appropriate line(s) below.
2. Complete and return ONLY this page of the package.
3. Make sure to place your submission number on your envelope and return it to the Purchasing Division

NOTE: It is required that you indicate your reason for not making a submission.

\_\_\_\_ We are not making a submission.

\_\_\_\_ We request that you remove our name from the mailing list for this offering only.

\_\_\_\_ We request that you remove our name from the mailing list for all future offerings made by the City.

VENDOR NAME: \_\_\_\_\_

ADDRESS: \_\_\_\_\_

CITY, STATE and ZIP CODE: \_\_\_\_\_

REASON FOR NOT MAKING A SUBMISSION:

\_\_\_\_\_  
\_\_\_\_\_  
\_\_\_\_\_  
\_\_\_\_\_

SIGNATURE: \_\_\_\_\_

# APPENDIX C

**INSTRUCTIONS FOR CITY OF NIAGARA FALLS**  
**STANDARD INSURANCE REQUIREMENTS**

**INSTRUCTIONS FOR CITY STANDARD INSURANCE REQUIREMENTS**

Standard Insurance Requirements apply to the following classifications:

- Construction and Maintenance
- Purchase of or lease of merchandise or equipment
- Professional Services
- Property leased to others or Use of Facilities or grounds
- Concessionaire Services
- Livery Services
- All-Purpose Public Entity Contracts

The Provider of any of the above classifications shall obtain, at his own costs and expense, the following insurance coverage with insurance companies licensed in the State of New York with a Best Rating of at least B+ and shall provide a Certificate of Insurance as evidence of such coverage to the CITY before commencement of work and/or lease or delivery of merchandise or equipment.

Certificates should be made to the City of Niagara Falls, NY, P.O. Box 69, Niagara Falls, N.Y. 14302-0069 and should reference the operation.

Prior to non-renewal, cancellation of insurance policies, or material change, at least 30 days advance written notice shall be given to the Certificate Holder.

All Certificates of Insurance shall be approved by the Corporation Counsel prior to the inception of any work.

Minimum coverage with limits and provisions are as follows:

**A. Comprehensive General Liability:**

With a minimum combined single limit of liability for Bodily Injury and Property Damage of \$1,500,000.00 per occurrence and \$3,000,000.00 annual aggregate. The coverage shall include:

- \*Premises and Operations
- \*Products and Completed Operations
- \*No exclusion for X C U coverages (explosion, collapse and underground)
- \*Independent Contractors
- \*Broad Form Property Damage
- \*Contractual Liability
- \*Fire Legal Liability
- \*Personal Injury Liability (Coverage A, B, and C)
- \*Liquor Liability (if alcoholic beverages are to be dispensed under NYS License.)

If the work to be performed is undertaken pursuant to a home improvement contract and a City of Niagara Falls right-of-way permit is required only by reason of the installation, repair or replacement of a driveway, apron, or sidewalk within the City right-of-way, then the limit of liability for comprehensive general liability set forth in this section shall be \$1,000,000 per occurrence and \$2,000,000 aggregate.

CITY shall be named as an Additional Insured on the General Liability Policy with the following provisions:

1. The insurance company or companies issuing the policies shall have no recourse against CITY for payment of any premiums or for assessments under any form of policy.

2. The insurance shall apply separately to each insured (except with respect to the limit of liability.)

B. **Auto Liability:** (if licensed vehicles are to be used in the operation)

With a combined single limit for Bodily Injury and Property Damage of \$1,000,000.00 each occurrence, the coverage shall include Owned, Hired and Non-owned autos (Symbol 1 should be designated for Liability Coverage on Business Auto Policy.)

C. **Excess Umbrella Liability:**

If General Liability and/or auto limits are lower than required in the above sections, Umbrella Liability or Excess Liability to the required limit is acceptable.

D. **Owners Protective Liability:** (for construction contracts with a cost exceeding \$100,000.00). With a minimum limit of \$1,500,000.00 each occurrence and \$3,000,000.00 aggregate. Named insured shall be City of Niagara Falls, NY.

E. **Professional Liability:**

If the contract includes professional services (engineers, architects, etc.), contractor will carry professional liability insurance with a minimum limit of one million dollars (\$1,000,000.00).

F. **Property Insurance:** (if applicable)

Contractor shall purchase and maintain property insurance upon the work at or off the site to 100% of the contract completed value. This insurance shall include the interest of the Owner, Contractor, and Subcontractors in the work; shall insure against the perils of fire and extended coverage; shall include "all risk" insurance for physical loss and damage including theft, vandalism and malicious mischief, collapse and water damage. All such insurance required by this Paragraph shall remain in effect until the Work is completed and accepted by the Owner.

G. **Statutory Worker's Compensation and Employers Liability:**

All contractors doing business with or vendors entering upon CITY property shall carry the above insurance, in compliance with the Worker's Compensation Law of the State of New York.

H. **Performance and Payment Bond:** (where applicable)

A performance and payment bond shall be issued by a Surety Company who is licensed by the Insurance Department of the State of New York in favor of CITY in the amount of not less than one hundred (100) per centum of the total amount of the accepted proposal and shall be delivered before commencement of lease or assumption of operations under Contract.

**NOTE: IF THE CONTRACT IS FOR PROFESSIONAL SERVICES ONLY (ENGINEERS, ARCHITECTS, ETC.), PARAGRAPHS D, F, AND H WILL NOT APPLY**

(Rev. 10/21)

# APPENDIX D

## SPECIFICATIONS AND DRAWINGS

**FIRE HYDRANTS, CATCH BASINS, MANHOLE  
FRAMES AND COVERS, VALVE BOX HEIGHT  
ADAPTERS AND CATCH BASIN FRAMES AND  
COVERS**

### **Fire Hydrant Specific Specifications**

- A) Hydrants and hydrant insert models (without shoe and frost jacket) for Matthews-Woods hydrants shall be Mueller Super Centurion or Kennedy Guardian models ONLY, and shall conform with all specifications herein composed. Hydrants and inserts shall also conform in all respects to the most recent A.W.W.A Standard C-502-XX, and be of the manufacturer's most recent improved design.
- B) The main valve must have a 5 ¼ inch valve opening, and the opening must be all bronze, pentagon shaped, 1 1/3 inches from flat to point.
- C) The main valve must open clockwise and the weather cap shall be affixed with an arrowcast to indicate direction to open.
- D) Hydrants must contain two hose nozzles, 2 ½ inches in diameter with National Standard Threads (NST).
- E) Hydrants must contain one (1) 4 inch steamer nozzle with NST flattened to 4-31/32 4TPI.
- F) All hydrants to be primed and finish coated N.F.P.A. Standard Chrome Yellow.
- G) The shoe inlet connection shall be a 6 inch mechanical joint, with all accessories, capable of accepting pipe with a 6.90 to 7.10 O.D. range. Accessories to include oversized gland, standard gasket, oversized gasket and all tee head bolts and nuts. All mechanical joint tee head bolts and nuts to be Corten (unless specified differently on bid sheet). Not applicable to insert.
- H) The operating nut for steamer and hose nozzle caps shall be 1 ½ inch pentagon.
- I) The hydrants must have a break away barrel and stem (otherwise known as a traffic model).



# VALVE BOX HEIGHT ADAPTER DIMENSIONS

## SLIDE-TYPE

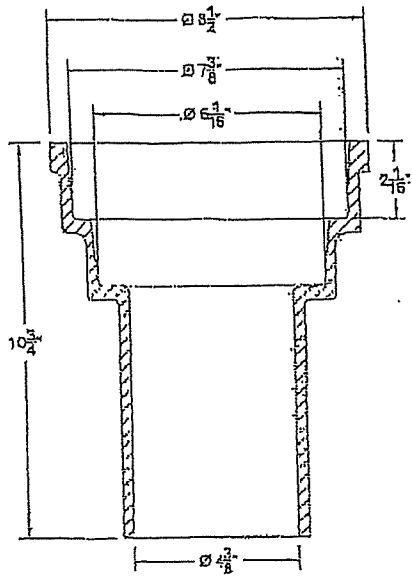

## SCREW-TYPE

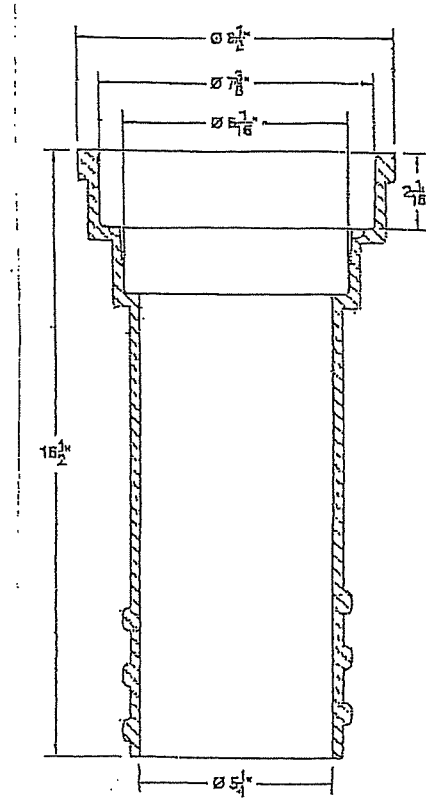

# CATCH BASINS

## INSIDE WALL DIMENSIONS

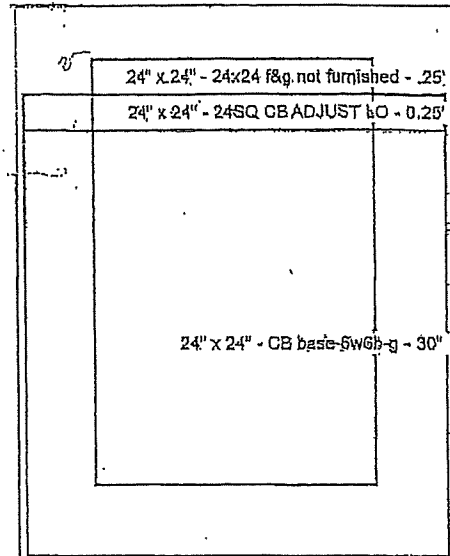
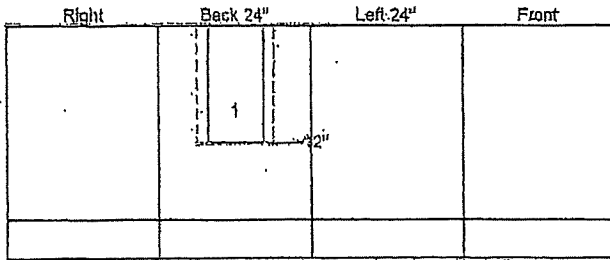

ELEVATIONS ARE CALCULATED BASED ON PIPES CENTERED IN OPENING

Position	Elev	Angle	Offset	Pipe	Pipe OD	Connector	UP ( )
Rim	3'						
Reducer							
Invert 1	1'	180°	0"	10" NO PIPE	10"	10" x 18" WEIR OPNG HOLE	12"
Invert 2							
Invert 3							
Invert 4							
Invert 5							
Invert 6							
Invert 7							
Invert 8							

### CB1 - 100

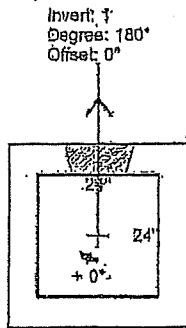

1) 24" x 24" - 24x24 f&g not furnished - .25'	0 lb
1) 24" x 24" - 24SQ CB ADJUST LO - 0.25'	0 lb
1) 24" x 24" - CB base 5w6h-g - 30"	2426 lb
1) 10" x 18" - WEIR OPNG HOLE	0 lb
1) Steps - NOT REQD	0 lb
2.5' VIF) NONE REQD [INT]	0 lb
3' VIF) NONE REQD [EXT]	0 lb
<b>Structural Total:</b>	<b>2426 lb</b>

Structure Notes: USE SPECIAL 10"W X 18"H HOLE  
TWO - 2 TON LIFTERS REQUIRED  
FLAT LIP JOINT ON TOP

Rim: 3' Invert: 1' Rim to Invert: 2' Catch: 1' Floor (Top): 0'	Floor (Bot): -0.5'	F, G, & ADJ:	0.5'	Project: NIAGARA FALLS WATER BOARD BASINS
Total Precast Ht:			3'	Location: NIAGARA FALLS, NY
Structure ID: CB1 Size: 24" x 24"			Spec: CATCH BASIN Type: SPECIAL	NIAGARA FALLS WATER BOARD
			Approved: R.R.	#: 22-154

MANHOLE FRAMES

15542000-1

B8

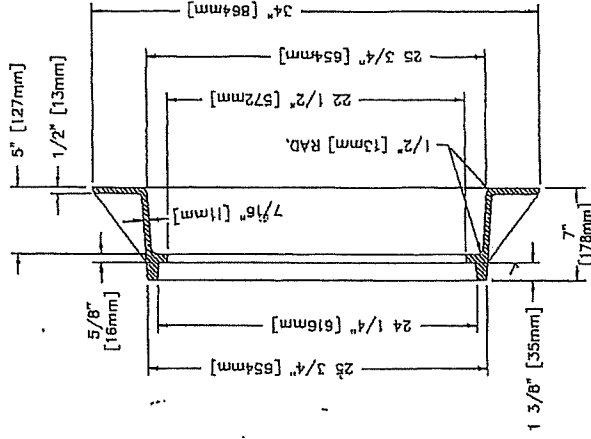
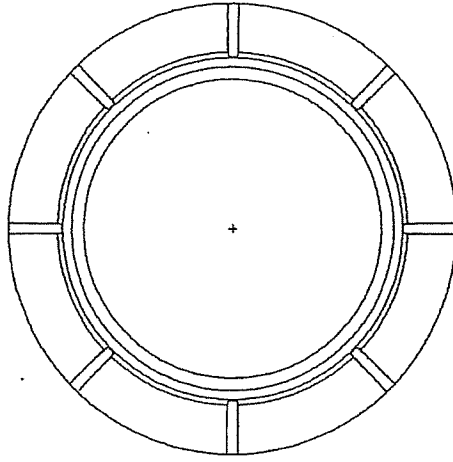

NOTE: ALL DIMENSIONS ARE SHOWN IN ENGLISH AND [METRIC]  
 MATERIAL: CAST GRAY IRON ASTM A-48, CLASS 35B  
 FINISH: NO PAINT  
 WEIGHT: FRAME - EST. 134#

DR.	E. REAME	SCALE	1/8" = 1"	TITLE	R-1554 FRAME
CHK.					
APP.					
DATE	2-10-95				
					NF-15542000 B <small>FOUNDRY COMPANY NEENAH WISCONSIN 54956</small>

MANHOLE COVER

15555002-2 B8

TYPE 'C' CHECKERED TOP LID DESIGN  
W/ PERMA-GRIP ANTI-SLIP SURFACE

1/2" LETTERS

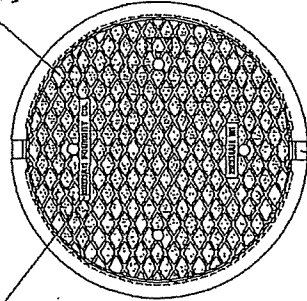

(2) CONCEALED PICKHOLES  
PER NF-22642

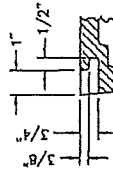

PICKHOLE DETAIL  
QUARTER SCALE

STACKING LUGS

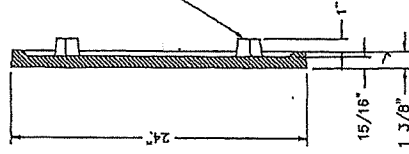

NOTE: ALL DIMENSIONS SHOWN ARE IN ENGLISH  
MATERIAL: CAST GRAY IRON ASTM A-48, CLASS 35B  
FINISH: NO PAINT  
WEIGHT: 121#

DR.		SCALE	TITLE
DL.		1/8"=1"	R-1555 PLATEN LID
APP.		DATE	NEENAH FOUNDRY COMPANY NEENAH, WISCONSIN 54956
DATE 06-19-1995		FILE	
DATE	BY	REVISION	NF-1555002 B
DATE	BY	REVISION	

CAD DWG. REF: 15555002.DWG- 2

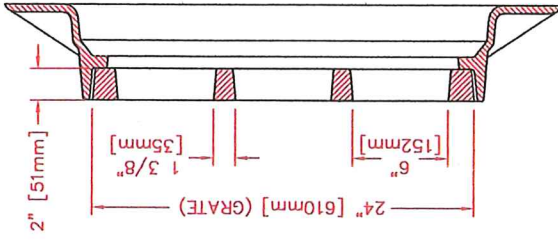
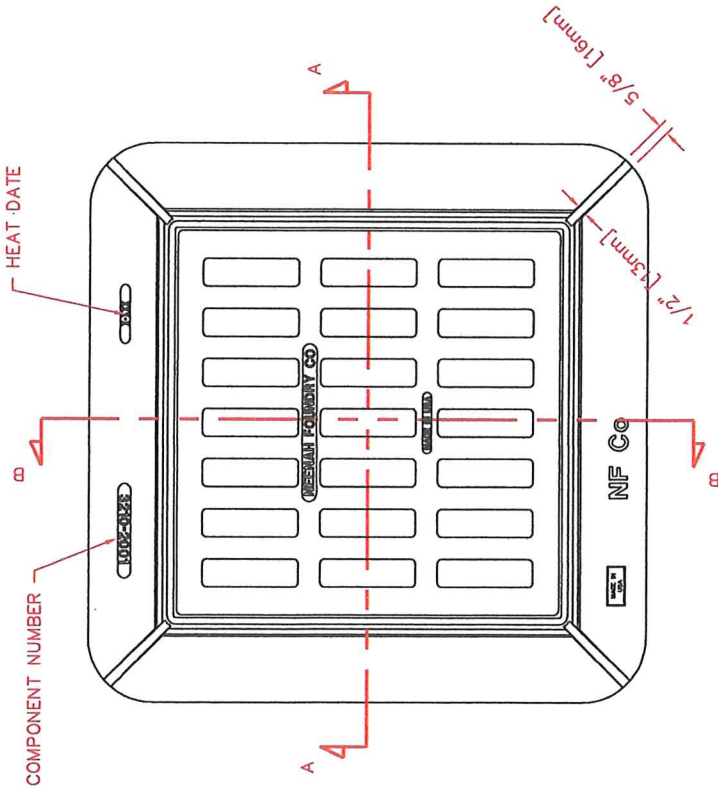

SECTION B-B

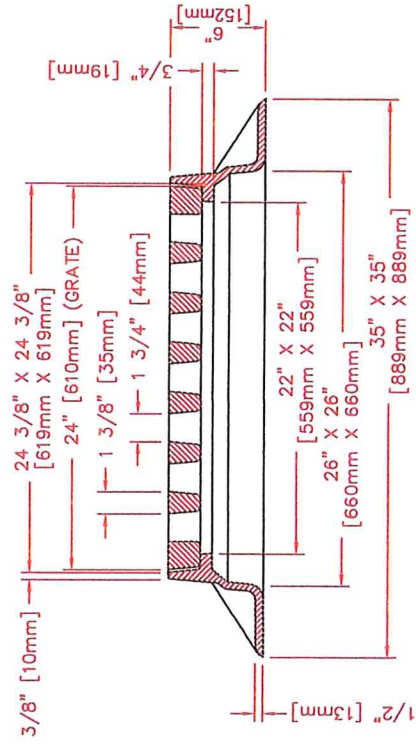

SECTION A-A

NOTE: ALL DIMENSIONS SHOWN ARE IN ENGLISH AND [METRIC].  
 COMPONENT NO'S: FRAME 3210-2001, GRATE 3210-0002  
 MATERIAL: CAST GRAY IRON ASTM A-48, CLASS 35B  
 FINISH: NO PAINT  
 WEIGHT: FRAME 164#, GRATE 166#

DR.	CSM	SCALE	TITLE
CH.		1 : 8	R-3433 FRAME AND GRATE
APP.		DIM CHK.	NEENAH FOUNDRY COMPANY NEENAH, WISCONSIN 54956
DATE	06-29-2010		

3"

1/2" [13mm] RAISED LETTERS  
FLUSH w/ TOP OF GRATE

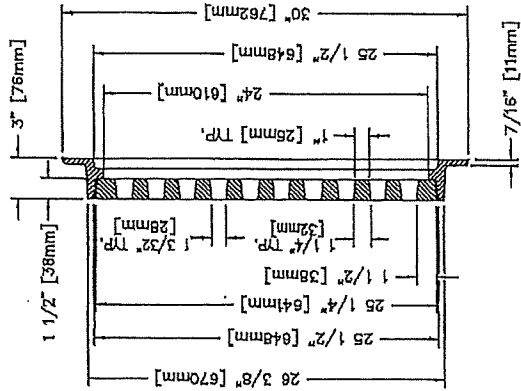
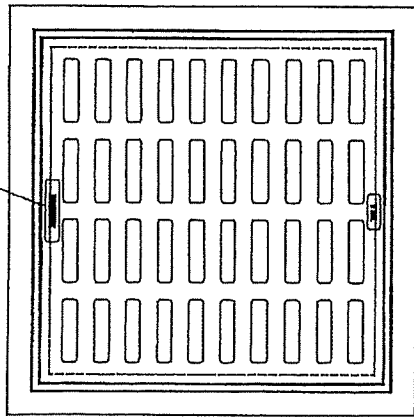

NOTE: ALL DIMENSIONS ARE SHOWN IN ENGLISH AND [METRIC]  
 CASTINGS ARE HEAVY DUTY H20 WHEEL LOAD  
 MEETS AASHTO M308 40,000 LB. PROOF LOAD  
 COMPONENT NO'S: FRAME 3560-2000; GRATE 3560-3000  
 MATERIAL: CAST GRAY IRON ASTM A-48, CLASS 35B  
 FINISH: NOT PAINTED  
 WEIGHT: FRAME - 79#, GRATE - 136#

DR.	CSK	SCALE	R-3560
CL.	CSK	1/8"=1"	FRAME AND GRATE
APP.	CSK	DATE	3-01-95
CHK.	CSK	DATE	3-01-95
APP.	CSK	DATE	3-01-95
CHK.	CSK	DATE	3-01-95
APP.	CSK	DATE	3-01-95

NEENAH  
 FOUNDRY COMPANY  
 KENOSHA, WISCONSIN 53102

NF-3560 400B

# 5945 Assembly

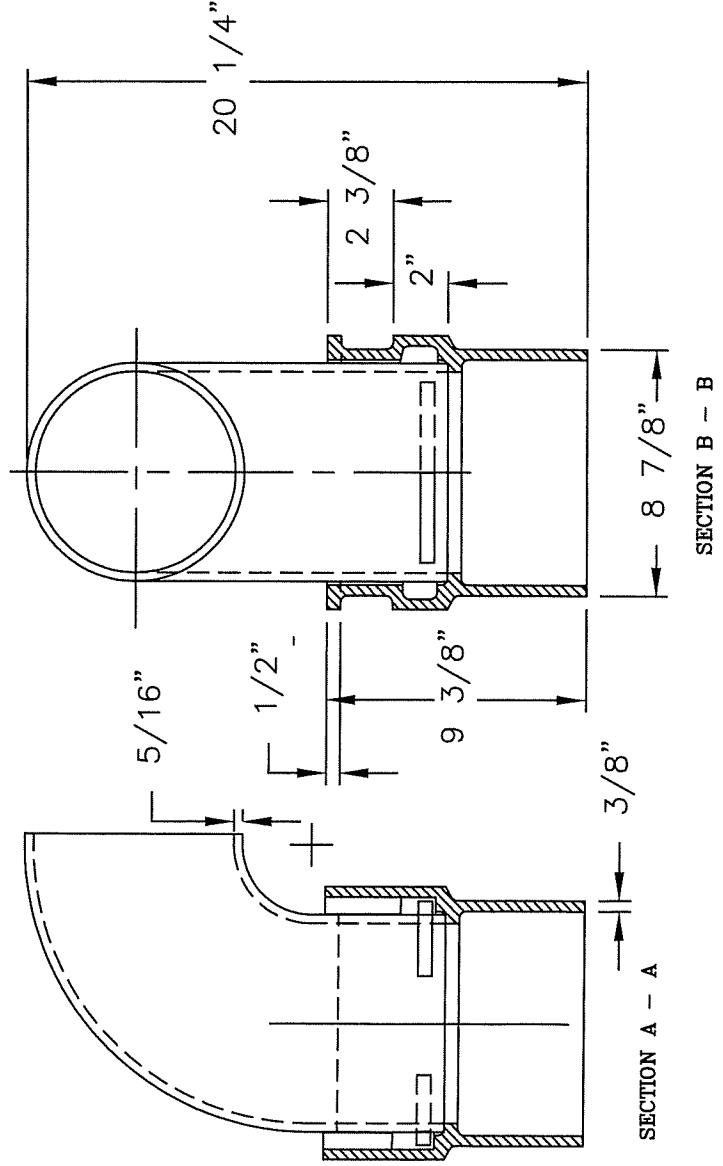
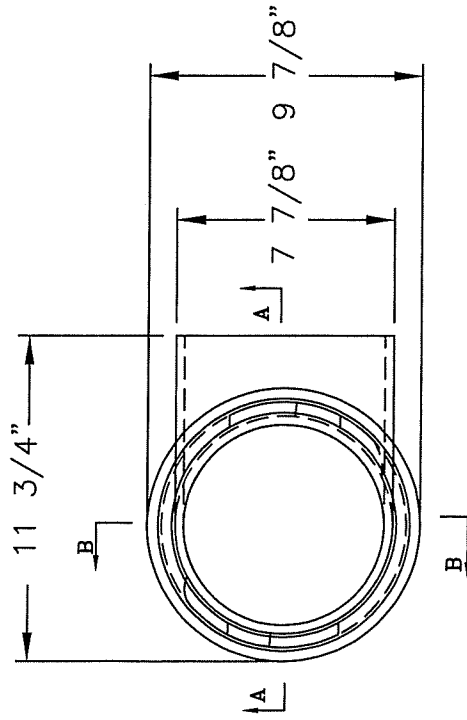

**Product Number**  
00594560A01

**Design Features**  
-Materials  
Catch Basin Trap  
Gray Iron (Cl.35B)  
Catch Basin Trap  
Gray Iron (Cl.35B)

-Design Load  
Heavy Duty  
-Open Area  
n/a  
-Coating  
Undipped  
-√ Designates Machined Surface

**Certification**  
-ASTM A48  
-Country of Origin: USA

**Major Components**  
00594560  
00594561

**Drawing Revision**  
6/22/2011 Designer: JJJ  
12/4/2013 Revised By: DAE

**Disclaimer**  
Weights (lbs./kg) dimensions (inches/mm) and drawings provided for your guidance. We reserve the right to modify specifications without prior notice.  
**CONFIDENTIAL:** This drawing is the property of EJ GROUP, Inc., and embodies confidential information, registered marks, patents, trade secret information, and/or know how that is the property of EJ GROUP, Inc. Copyright © 2012 EJ GROUP, Inc. All rights reserved.

**Contact**  
800 626 4653  
ejco.com

**Specifications for the solid manhole riser rings are as follows:**

- a) Rings shall be made from A-36 hot rolled steel with the upper and lower sections continuously welded;
- b) The three (3) sizes required shall be 24" x 1" by 1.0 ; 24" x 1" by 1.5"; and 24" x 1" by 2.0" with all tolerance areas +/- 1/16" as per the drawing below; and
- c) Materials are to conform with SPEC A.S.T.M.-A-575 MQ with acceptable dimensional characteristics for loads exerted by heavy vehicular traffic (HS-20).

Rings shall also conform to this drawing:

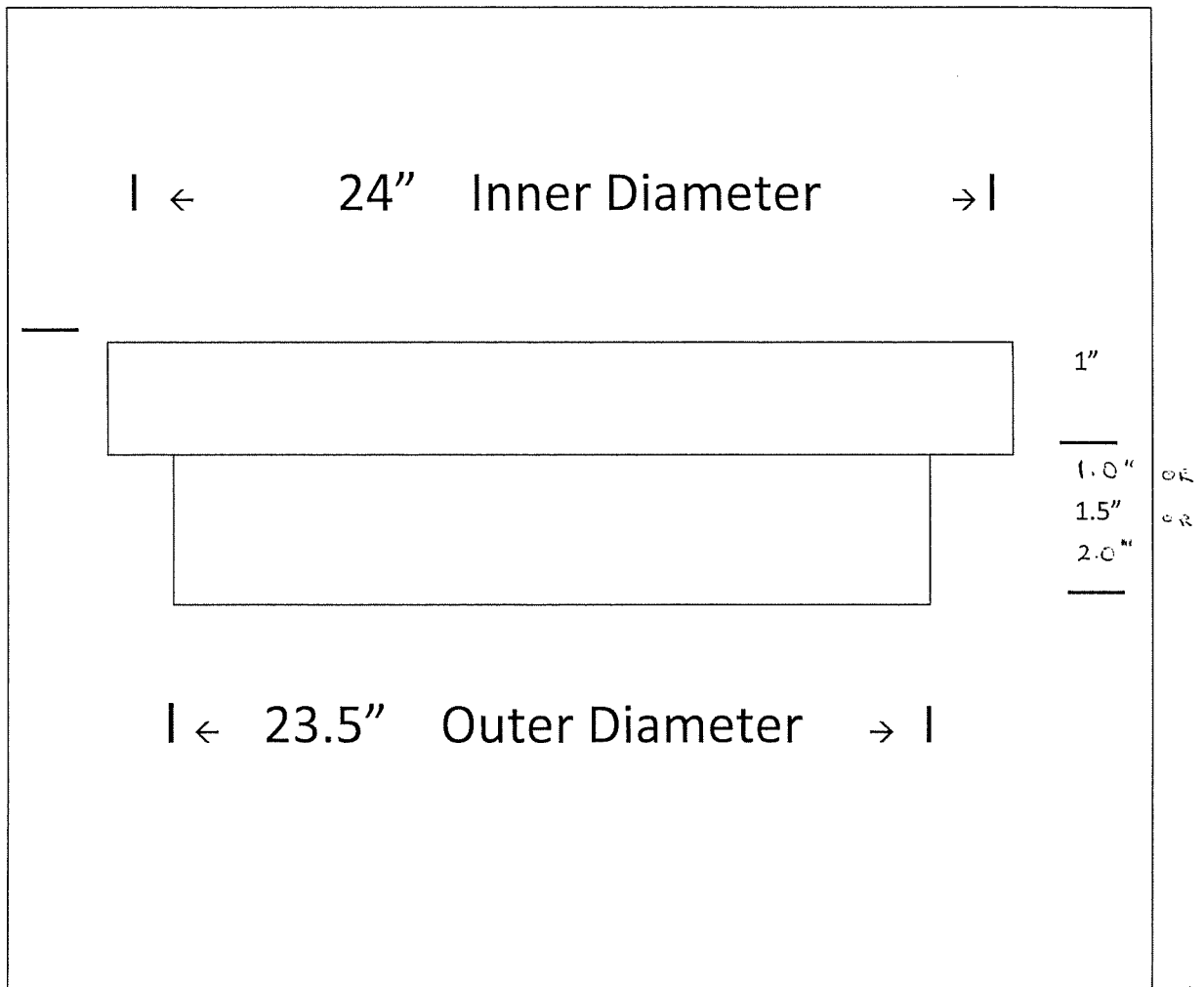



**THIS PAGE INTENTIONALLY LEFT BLANK**